

Using Circuit Design Software to Simulate Mechanical Components

Oleksandr Beznosyk, Oleksii Finogenov, Volodymyr Ladogubets, Oleksii Tchkalov

Abstract – In the paper the possibility of using circuit design software to simulate mechanical components is considered.

Keywords – Simulation, ANSYS, NetALLTED, mor4ansys, RLC-reduction.

I. INTRODUCTION

A possibility to use integrated tools for modelling objects in which various physical processes (electric, mechanical, optical, thermal, etc.) occur plays an important role when designing modern MEMS devices. It requires various subsystems of initial object to be presented as equivalent models of the same physical nature that will allow joining them to solve in the single computing process. However the most widespread CAD systems, as usual, use the single-aspect simulation, for example, Spice to analyse electronic circuits or Adams for virtual modelling complex machines and mechanisms. There are some approaches to calculate "non-traditional" for the given systems physical processes: taking into account physical features as additional parameters of base models; inclusion of the opportunity of calculation in additional bases, typical for other physical processes, etc.

At a stage of circuit simulation, the method of electromechanical analogies is most often applying to form a mathematical model of an object of the complex physical nature. It, in turn, requires availability of circuit realizations of non-electric blocks' models featured with a necessary accuracy degree. The majority of the modern CAD tools applied to design mechanical systems use a finite-element method to construct a mathematical model. The basic problem to use such models is dimension of received systems which can reach tens of thousands equations. Therefore the main efforts of developers are directed to obtaining the reduced models suitable for further use.

So, the development of an algorithm to obtain models of non-electric objects as equivalent electric circuits for further use in circuit design software on the basis of existing tools for mathematical model formation is actual.

II. EXAMPLE DESCRIPTION

Let's consider a method of construction of circuit models of mechanical components and their further use by an example of a problem of finding eigenfrequencies of a beam (Fig. 1).

The considered construction represents a beam working on a bending. The left end of the beam is fixed motionlessly, right one is free. Force F is applied to the right end perpendicularly to the beam axe.

To construct a mathematic model, ANSYS Multiphysics

Oleksandr Beznosyk, Volodymyr Ladogubets, Oleksii Finogenov – CAD Department, System Research Faculty, NTUU "KPI", 19, Panasa Myrnogo Str., Kyiv, 01011, UKRAINE, e-mail: sasha@cad.kiev.ua; Oleksii Tchkalov – Theoretical Mechanics Department, Aerospace Systems Faculty, NTUU "KPI", 37, Peremogy Ave., Kyiv, 03056, UKRAINE

v.10.0 software developed by ANSYS Inc. [1] was used. ANSYS simulation took place under the following parameters: $L = 25$ mkm; beam cross-section is a square one with height of 3 mkm and width of 2 mkm. Beam material properties: coefficient of elasticity $E = 2 \cdot 10^{11}$ Pa = 0.2 N/mkm²; Poisson coefficient $\mu = 0.3$; material density $\rho = 6 \cdot 10^3$ kg/m³ = $6 \cdot 10^{-9}$ mg/mkm³.

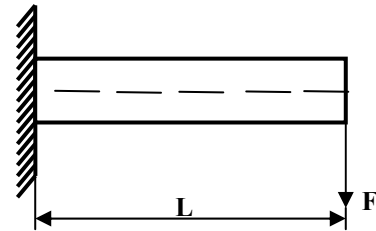

Fig. 1 Beam scheme.

For discretization of the beam, ANSYS library's BEAM3 finite elements have been used. Every beam element has two nodes (left/right) with three degrees of freedom in each one: coordinates x, y in a plane of motion and a corresponding beam cross-section's turn angle θ . All the elements have identical length of 0.5 microns. So, the design model consists of 50 beam elements and 51 nodes.

III. EQUIVALENT CIRCUIT

For the mechanical component in question, the matrices in MarketMatrix format describing the system status have been received from ANSYS project files (FULL and EMAT) by means of the mor4ansys program [2].

Matrices are coefficients of the equation

$$M\ddot{x} + D\dot{x} + Kx = BF, y = Cx,$$

where M, D and K are mass, damping and stiffness matrices respectively; B is an input matrix; C is an output matrix; x is a unknowns' vector, including all degrees of freedom; F is a force vector and y is an output variables' vector.

Proceeding to the electromechanical analogies [3], it looks like:

$$\frac{d}{dt}(Mv) + Dv + \int Kvdv = F(t)$$

or

$$\tilde{C}\dot{v} + \tilde{G}v + \tilde{L}v = F(t),$$

where $\tilde{C} = M, \tilde{G} = D, \tilde{L} = K$ are equivalent matrices of capacitances, conductances and inductances. Elements of $C, G,$ and L matrices are to be formed from elements of matrices $M, D,$ and K by formulas:

$$C_{ij} = -m_{ij}, \quad i, j = 1(1)N, \quad i \neq j$$

$$C_{ii} = \sum_{j=1}^N m_{ij}, \quad i = 1(1)N.$$

$$L_{ij} = -1/k_{ij}, \quad i, j = 1(1)N, \quad i \neq j$$

$$L_{ii} = 1/\sum_{j=1}^N k_{ij}, \quad i = 1(1)N.$$

$$G_{ij} = -d_{ij}, \quad i, j = 1(1)N, \quad i \neq j$$

$$G_{ii} = \sum_{j=1}^N d_{ij}, \quad i = 1(1)N.$$

where N is a quantity of the equations for the system in question. Using received matrices C , G , and L , it is possible to proceed to an equivalent circuit. Sometimes, some of these matrices can be absent. It means there are no corresponding elements in the circuit. For the considered example, the equivalent circuit is presented on Fig. 2.

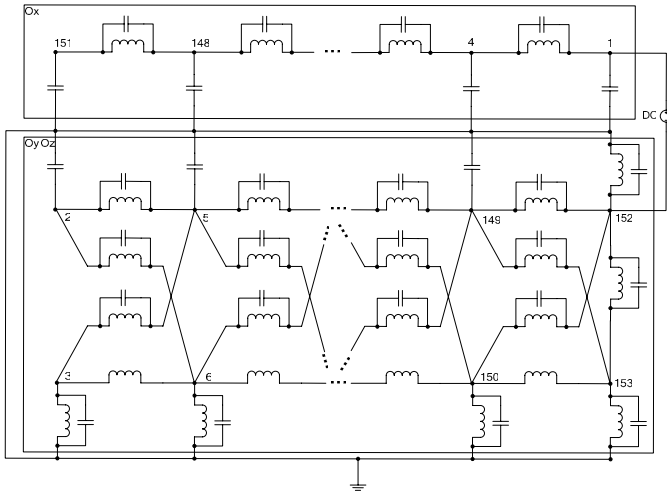

Fig. 2 Beam equivalent circuit.

In the given circuit, subcircuits "Ox" and "Oy,Oz" are connected only by zero node of the circuit. It is obvious that if one source is connected to the mechanical equivalent's force application node, frequencies of one of subcircuits will be observed only. So, for the presented example, when connecting a source between nodes of 151, 0, frequencies corresponding to the mechanical model's tensioning eigenfrequencies will be observed. In the case of a source connected between nodes of 152, 0, output characteristic will contain only the frequencies corresponding to the bending eigenfrequencies. From the mechanics point of view, such a situation represents two independent directions the initial force vector is distributed on. For the equivalent circuit it means inclusion of a source between subcircuits, or inclusion of two sources for excitation of corresponding subcircuits.

IV. CIRCUIT DIMENSION REDUCTION

For the objects with complex geometry and a lot of degrees of freedom the finite-element model can contain hundreds of thousands equations. In this case the equivalent circuit can

contain millions and more elements. This circumstance makes it impossible to use the given circuit as a model of the object, so it is expedient to take advantage of algorithms of reduction of circuit dimension on the basis of Y- Δ transformation.

The essence of the methods based on the Y- Δ transformation consists in the following. Let's i -th node and its k neighbours are located as shown on Fig. 3. Then, the component equation of i -th row looks like:

$$Y_i V_i - y_1 V_1 - y_2 V_2 - \dots - y_n V_n = 0, \quad (1)$$

where $Y_i = \sum_{j=1}^k y_j$.

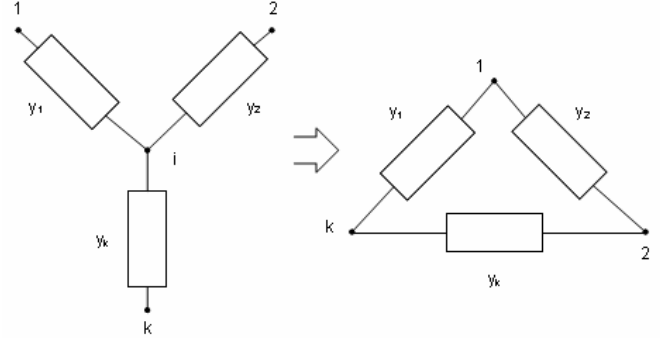

Fig. 3. A work node of RLC circuit. Addition of a conductance between node 1 and nodes next to i -th.

To exclude V_i from (1), that is equivalent to excluding i -th node, let's define V_i as:

$$V_i = \left(\sum_{j=1}^k y_j V_j \right) / Y_i \quad (2)$$

and replace V_i with (2) at k equations, where it is present. Let's consider a first node, which will be next to i -th, and its equation looks like:

$$\left(\bar{Y}_1 + y_1 - y_1^2 / Y_i \right) V_1 - \left(\sum_{j=2}^k y_1 y_j V_j \right) / Y_i - \sum_{\substack{r=1 \\ r \neq i}}^{kl} y_r V_r = 0 \quad (3)$$

where $\bar{Y}_1 = \sum_{\substack{r=1 \\ r \neq i}}^{kl} y_r$ is a sum of all node one's conductances

excluding i -th node, kl is a number of nodes, connected to node 1.

Eq. (3) can be simplified:

$$\left(\bar{Y}_1 + \left(\sum_{j=2}^k y_1 y_j \right) / Y_i \right) V_1 - \left(\sum_{j=2}^k y_1 y_j V_j \right) / Y_i - \sum_{\substack{r=1 \\ r \neq i}}^{kl} y_r V_r = 0$$

Note that it is equivalent to adding $k-1$ new elements between first node and $k-1$ former neighbours of i -th node on Fig. 3.

For any two nodes next to i -th, for example a and b , excluding of i -th node leads to adding a new element between these nodes. Conductance of this element will be equal to:

$$y_{ab} = (y_a y_b) / Y_i$$

So, repeating this process for all k neighbours of i -th node, we remove it thereby.

For each node in the circuit, there are two time constants defined:

$$\tau_{RCi} = C_i / G_i \text{ and } \tau_{LCi} = \sqrt{C_i / B_i},$$

where $C_i = \sum_{j=1}^k c_j$ is a sum of all capacitances connected to

node i , $B_i = \sum_{j=1}^k b_j$ is a sum of all reactive conductances (the

value reverse to inductance) connected to node i , and

$G_i = \sum_{j=1}^k g_j$ is a sum of all conductances connected to node i .

So, i node's time constant is:

$$\tau_i = \max(\tau_{RCi}, \tau_{LCi}).$$

i -th node is considered to be fast if:

$$\tau_i < \tau_{\min} = 2\pi / \omega_{\max},$$

where τ_{\min} is a user-defined time constant, which depends on the maximal frequency of the circuit – ω_{\max} . Note that the τ_{\min} constant is proportional to $1/\omega_{\max}$. Thus, if i -th node is a fast one it can be removed from the circuit as described above. (More details about reduction algorithms based on the Y- Δ transformation are in [4,5,6].)

In practice, the lower eigenfrequencies, which are work ones for mechanical systems, is of interest usually. Therefore, a compromise between accuracy and dimension of received models can be reached by the variation of τ_{\min} .

V. SIMULATION RESULTS

The four lower eigenfrequencies of the construction in the range of 14 MHz up to 120 MHz are defined by computation. The results of ANSYS Multiphysics frequency analysis as well as the results of simulation of the equivalent and reduced under the different values of τ_{\min} circuits in NetALLTED [7,8] are presented in Table I. The output characteristics of the equivalent and reduced circuits for the frequency range of 14 MHz – 120 MHz are presented on Figs. 4-7.

The ANSYS and NetALLTED simulation results coincide that confirms the transition from a model obtained by finite-element method to an equivalent circuit do not bring in an additional error. As it is seen from Table I, circuit simulation error under $\tau_{\min} = 2 \cdot 10^{-4}$ as compared to the ANSYS results is less than 1% that confirms a high precision of the obtained model. Meanwhile, the dimension of the reduced model in

comparison with the equivalent one reduced more than 5 times.

TABLE I
SIMULATION RESULTS

	ANSYS	NetALLTED			
		Equivalent circuit	Reduced circuit		
τ_{\min}	-	-	$8 \cdot 10^{-4}$	$4 \cdot 10^{-4}$	$2 \cdot 10^{-4}$
Node number	-	154	11	15	27
Element number	-	862	66	94	256
Node reduction, %	-	-	92.8571	90.2597	82.4675
Element reduction, %	-	-	92.3434	89.0951	70.3016
1 st peak, MHz	18.745	18.745	18.955	18.724	18.788
2 nd peak, MHz	50.890	50.890	52.613	50.458	51.028
3 rd peak, MHz	97.860	97.859	101.75	95.937	97.955
4 th peak, MHz	115.49	115.49	107.2	112.88	114.93
Maximal error, %	-	-	7.18	2.26	0.48

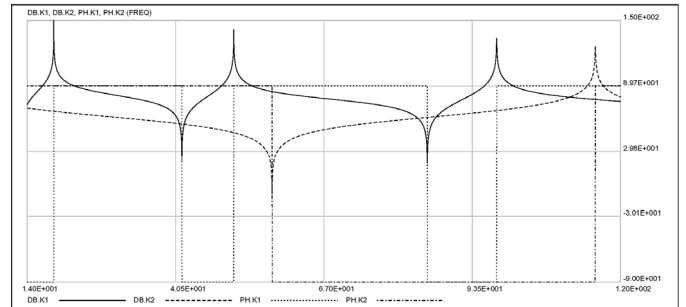

Fig. 4 AFC, PFC of the equivalent circuit.

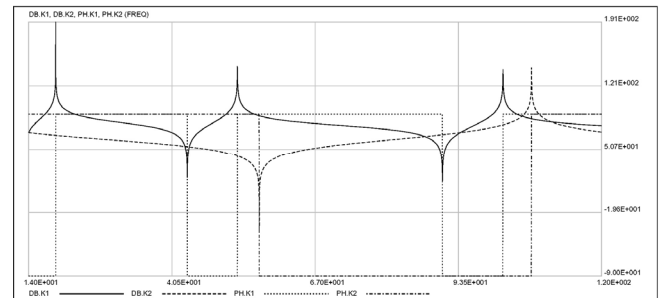

Fig. 5 AFC, PFC of the reduced circuit, $\tau_{\min} = 8 \cdot 10^{-4}$.

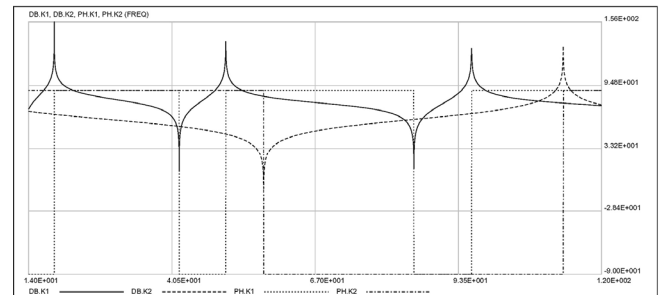

Fig. 6 AFC, PFC of the reduced circuit, $\tau_{\min} = 4 \cdot 10^{-4}$.

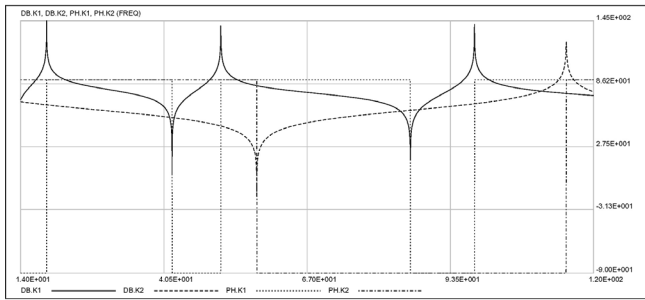

Fig. 7 AFC, PFC of the reduced circuit, $\tau_{\min} = 2 \cdot 10^{-4}$.

REFERENCES

- [1] Ansys Inc.: <http://www.ansys.com/>.
- [2] E. Rudnyi, J. Lienemann, A. Greiner, J. G. Korvink, "mor4ansys: Generating Compact Models Directly from ANSYS Models", *Technical Proceedings of the 2004 Nanotechnology Conference and Trade Show (Nanotech 2004, March 7-11, 2004)*, Boston, Massachusetts, USA, vol. 2, pp. 279-282.
- [3] J. T. Hsu, L. Vu-Quoc, "A rational formulation of thermal circuit models for electrothermal simulation. – part 1: Finite element method", *IEEE Transactions on Circuits and Systems – I: Fundamental Theory and Applications*, vol. 43, pp. 721-732, 1996.
- [4] Ю. А. Руденко, В. В. Ладогубец, А. В. Ладогубец, "Алгоритм уменьшения размерности RLC цепей", *Электроника и связь*, 2004, №21, с. 72-74.
- [5] Sheehan B.N. TICER: Realizable Reduction of Extracted RC Circuits // Digest of Technical Papers IEEE/ACM Proc. of ICCAD. – 1999. – p. 200-203.
- [6] S. A. Chirayu, H. C. Masud, I. I., "Yehea Realizable RLCK Circuit Crunching", *Proceedings of the 40th conference on design automation*, Anaheim, CA, USA, 2003, pp. 226-231.
- [7] A. Petrenko, V. Ladogubets, V. Tchkalov, Z. Pudlowski, *ALLTED – a computer-aided engineering system for electronic circuit design*. Melbourne: UICEE, 1997, 205 p.
- [8] А. І. Петренко, "Мережний пакет для комп'ютерного проектування мікроелектромеханічних систем (MEMC)", *Розвиток інформаційно-комунікаційних технологій та розбудова інформаційного суспільства в Україні*. К.: Зв'язок, 2007, с. 143-156.

VI. CONCLUSION

The method to construct models of mechanical components presented in the paper allows using circuit design software as integrated tools for simulation of electromechanical devices. Use of the Y- Δ transformation-based reduction allows receiving models with the required accuracy degree not yielding at the equivalent circuit obtaining stage to the accuracy of the mathematical model received by means of the finite-element method. The method offered can be used for MEMS calculation, and in the general case it can be expanded on the non-mechanical nature objects too if their mathematical model can be received in the form of finite-element matrices.